

第 XXXI 部

JGNv6 プロジェクト

第 31 部

JGNv6 プロジェクト

第 1 章 Introduction

In order to come up with the various technical and operational challenges due to the continuous and rapid growth of the Internet, the research and development on the IP version 6 (IPv6) have been progressed for more than ten years. The IPv6 team of JB Project has worked with Telecommunications Advancement Organization of Japan (TAO), so as to achieve the successful upgrade of the Japan's nation-wide Gigabit Network (JGN: Japan Gigabit Network) to be compatible with IP version 6 (IPv6). This JGN IPv6 network has 47 access points across nation-wide Japan; including 28 router installation sites.

With this deployment, an IPv6 network has been developed enabling the execution of various verification and operation experiments, such as early transition of the network from IPv4 to IPv6 and the debugging of commercial products in order to be compatible with IPv6 and to achieve the professional operational quality.

For the next generation very high-speed network, the TAO has established a gigabit network for research and development in 1998. JGN, Japan Gigabit Network, aims to contribute the research and development of network operation and management technologies, and advanced application technologies. JGN is an open research and development network for various research organizations, e.g., governmental agencies, or enterprises, as well as universities and research agencies[280].

To enable the JGN to accommodate various research and development activities related to IPv6 technology, which is a core network protocol

for the next generation Internet. Network equipments compatible with IPv6 has been installed and a test operation as a JGN IPv6 network has started on October 1, 2001.

It is said that IPv6 can provide;

- Various functions, such as security, reliability, which are required for emerging communication infrastructure
- Address space, which is necessary and sufficient to preserve the end-to-end model.

IPv6 has also been designed to cope with various technical challenges arising from Internet protocol version 4, such as the problem of scarcity of IP addresses and increase in the number of routes in the Internet backbone.

Most of IPv6 standardization has been achieved part several years ago, to introduce the IP version 6 to the real production network (RFC2460), ICMPv6 (RFC2463). In these days, various kinds of functions for the configuration and operation of the IPv6 network have been standardized and those functions have started to be implemented by various commercial router vendors.

The JGN IPv6 network has been established as a native IPv6 network equipped only with IPv6-compatible equipments. And, JGN allows IPv4 traffic via IPv4/IPv6 dual-stack operation, i.e., capable of accommodating both IPv4 and IPv6. In order to contribute to the router vendors, JGN IPv6 network is operated with a multi-vendor environment that includes two US vendors and three Japanese router vendors. JGN IPv6 network contains the Okayama IPv6 Interoperability and Evaluation Laboratory. In the laboratory, we evaluate each network equipments and application software. The evaluation is functional compliancy of each equipment and interoperability among the network equipments. Also, the JGN IPv6 network has the IPv6 Research and Operation Center in Tokyo (Otemachi), in order

to establish the operation and management technologies of the IPv6-compatible network equipments.

connected to one of the four core sites, and the bridge sites are connected to one of the router sites, respectively (Figure 2.1).

第 2 章 Overview of JGN IPv6 network

2.1 Network Topology

JGN networks use ATM technology for datalink, and therefore, the JGN IPv6 network is sitting on the JGN's ATM network. JGN IPv6 network has been constructed with 57 operational sites, which are 28 router sites and 29 bridge sites. Among the router installation sites, we have four of core sites, i.e., the University of Tokyo, Teleport Okayama (in which the Okayama IPv6 Interoperability and Evaluation Laboratory is also set up), Dojima and the Kyushu University. Four core sites are interconnected to configure the backbone of the JGN IPv6 network. Other router sites are

2.2 Multi-vendor Environment

In order to establish the operational technologies and validate the interoperability among the routers manufactured by various vendors, the JGN IPv6 network contains different types of routers from five router vendors (See Table 2.1). Every router is commercial router that is compatible with IPv6 functionality, though the software running in each router is sometime beta-code or alpha-code directly provided by each vendor. Each router vendor has their own interpretation for each protocol specification to have different implementation. Each router vendor has their implementation priority regarding the protocols and functions that should be implemented as the IPv6 system. Therefore, it was sometime hard that all routers in the JGN IPv6 network has the same functionality and has the

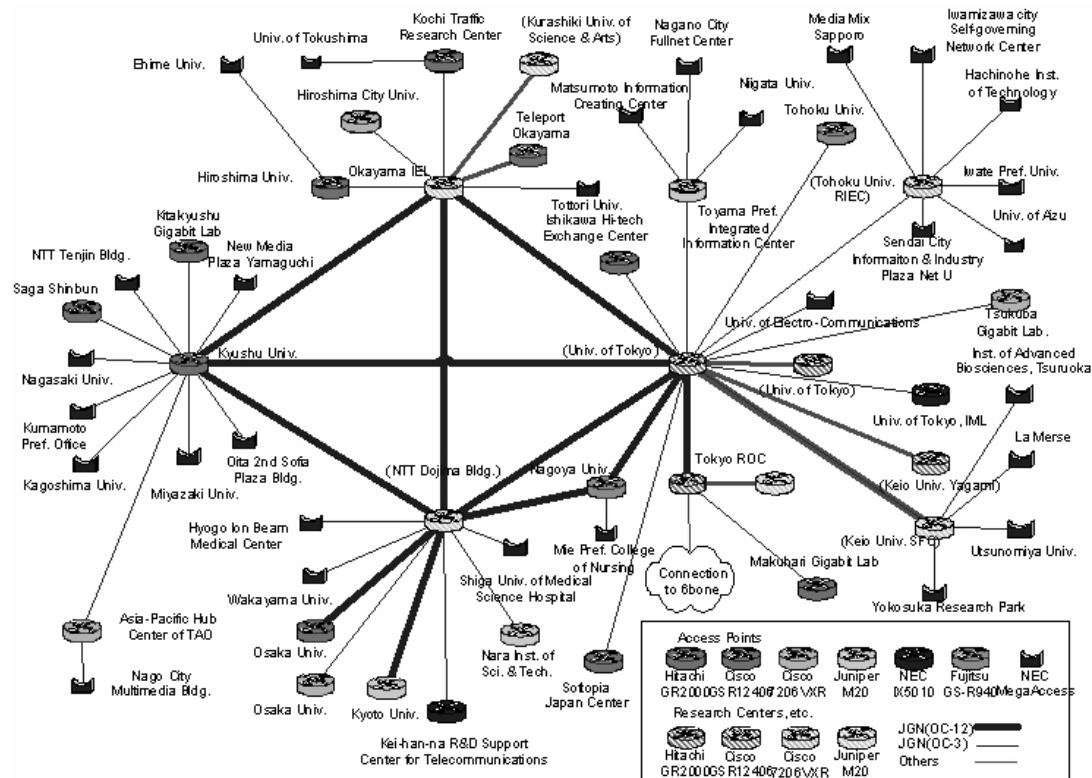

Fig. 2.1. JGN IPv6 Network Topology

interoperability. For example, regarding the IGP (Interior Gateway Protocol), US vendors have implemented IS-IS first, however, Japanese vendors have implemented OSPF first. With these diversity of functional and protocol implementation for each router vendors, we had to have serious consideration and coordination so as to operate every function and every protocol.

2.3 Routing Configuration

The JGN IPv6 network has partially inherited topological characteristics of the underlying ATM network. However, using the ATM virtual path (PVC), the logical network topology for layer 3 (IPv6) has been configured and sometime re-configured. The current layer 3 network topology has been designed to establish the JGN IPv6 network easily for starting the stable initial operation. So that, the current layer 3 network topology is basically hub-and-spoke with four hubs (i.e., four core sites with hierarchical topology). Router sites and bridge sites, excepting the core sites, are single-homing to each of their upstream site. According to the testing and evaluating items, the layer 3 network topology will be modified, when we need.

Regarding the external connectivity, JGN IPv6 network uses BGP4+ for peering with other IPv6 networks. The JGN IPv6 network is connected to the WIDE NSPIXP-6[216] (Otemachi, Tokyo), and is also connected to 6Bone, which is a global IPv6 experimental network. Regarding connection with other IPv6 networks, connection with local IXs, such as NSPIXP-3 (Dojima, Osaka) and OKIX (Okayama), is also being considered. The current JGN IPv6 network (as of October 18,

2002) has the following 11 peerings;

- WIDE Project (AS 2500)
- KDDI (AS 2516)
- Netsurf (AS 4675)
- FINE (AS 4678)
- MIND (AS 4680)
- PoweredCom (AS 4716)
- APAN Tokyo-XP (AS 7660)
- KDDI Laboratories (AS 7667)
- IPv6 Promotion Council Network (AS 17935)
- APII (AS 18083)
- NTT DoCoMo (AS 18262)

As for the IGP (Interior Gateway Protocol), we have to use RIPng rather than OSPF or IS-IS. This is simply because not all routers installed in the JGN IPv6 network support OSPF nor IS-IS. Finally, at this moment of time, JGN IPv6 network has not applied the multicast routing protocol. We are going to introduce the PIM-SM with IPv6, whenever all routers installed in the JGN IPv6 network support it. Some routers have already implemented the PIM-SM to make sure the interoperability among them, however some routers have not implemented yet.

Whenever all routers are ready to enable OSPF (i.e., OSPFv3) or PIM-SM with IPv6, we will start to run these routing protocols on the JGN IPv6 network. An IPv6 address block employed in the JGN IPv6 network uses the NLA addresses (3ffe:516::/32) in a pTLA address block allocated by the WIDE Project[319]. A method for assigning addresses to each of the router site and the bridge site is recognized as one of the experiments associated with IPv6 operation. Although we use the WIDE NLA address space, JGN IPv6 network obtains own AS (Autonomous System) number

Table 2.1. Routers in JGN IPv6 network

Vendor name	Product name	Number of routers
Cisco Systems	GSR12406	3
	7200VXR	6
Juniper Networks	M20	8
Hitachi Ltd.	GR2000-6H	13
Fujitsu Ltd.	GeoStream R-940	3
NEC	IX5010	3

(i.e., AS 17394), so that we can run experiments on exchange of the BGP routing information with other IPv6 networks.

2.4 Installation of Network Equipments

Among the 57 operation sites, 47 operation sites excluding some sites for research facilities are publicly opened as the access points (POP). Each access point provides IPv6 connectivity via Ethernet (10/100 Mbps) to the JGN IPv6 network user.

At each access point of the router sites, router, that has been compatible to IPv6, and an Ethernet switch accommodating the users are installed. Any user, who want to use the access point at the router site requests to interconnect to the JGN IPv6 network via Ethernet switch (10-/100BASE-T). At each router site, an address space of /48 is allocated for a segment for user accommodation. The bridge site provides an environment in which IPv6 can be used by extending the IPv6 segment (datalink). In order to bridge between the router site and bridge site, we use the ATM-Ethernet bridge.

2.5 Network operation policy

In the JGN IPv6 network, the actual network operation and a monitoring work of the network itself deserve experimental approaches. Therefore, in the JGN IPv6 network, router installation sites have been newly set up at several locations that differ from the JGN IPv4 network access points that TAO has developed so far. By engaging in the daily operation of the network, the user is afforded the opportunity to learn network operation technologies of IPv6 different from those of IPv4.

In the Internet, an operation form not assumed by a developer is often adopted. It is expected that with direct feedback from plural network administrators in the JGN IPv6 network, potential problems can be found at early stages. Tools and instrumentation systems for evaluating the compatibility and performance of IPv6 are also lacking and continue to do so. We, WIDE Project,

have addressed the research and development of IPv6 from the early days. There have been many projects conducted: the KAME project[146] in which a program is being developed for providing an IPv6 stack for PC-UNIXs such as FreeBSD and NetBSD, the USAGI project[304] targeting Linux, the TAHI project[277] aiming at the exact implementation verification of IPv6, etc. In the JGN IPv6, it is necessary for as much cooperative work to be conducted with these projects as possible and for the technologies to be shared so that IPv6 is popularized early. For that purpose, it is very important to store and share not only direct research achievements, but also information with respect to the processes in which these are obtained.

第 3 章 Verification and Evaluation of Interoperability

The current IPv6-compatible router equipments do not have full interoperability performance among those equipments manufactured by various vendors. Frankly saying, the capability of interoperability among IPv6 equipments would be similar to the status of IPv4 in ten years ago.

The JGN IPv6 project executes the verification and evaluation of interoperability among the IPv6-compatible router equipments. For this research purpose, we have established the Okayama IPv6 Interoperability and Evaluation Laboratory. All pieces of the router equipments, that have been introduced in the JGN IPv6 network, are installed in the laboratory so as to be executed verification and evaluation. After the verification and evaluation at the laboratory, only the equipments working correctly and having the interoperability with other equipments are introduced into the JGN IPv6 network.

The following items would be verification and evaluation items:

- Verification of accuracy and compliancy of

IPv6 functions and performance evaluation

- Verification of interoperability between equipments supplied by various vendors
- Verification of availability and compatibility among equipments
- Verification of stability, failure tolerance, and etc.
- Verification of functions when being in a redundant network topology.

The IPv6-compatible router from each manufacturer experiences fairly frequent version up. This is because each manufacturer wants to implement a new function of IPv6 as much as and as fast as possible. They are fixing the technical problems for the software implementation at the router software with a short turn-around periods.

第4章 Management Technology of IPv6 network

Since SNMPv3[25], which is a network management protocol compatible with IPv6, is in the process of being standardized at the IETF, it would be hard that the router products provided by the manufacturers are equipped with an IPv6-based network management capability. Similarly, almost all products of network management applications do not have an acceptable compatibility with IPv6. At least, the JGN IPv6 network should have the following functions;

- Capability to collect traffic information of an interface with an IPv6 address
- Capability to perform correct address notation corresponding to 128 bits,

The IPv6 Research and Operation Center in Otemachi (Tokyo) is in charge of the development of software required for operation and management for the actual operation of the JGN IPv6 network. The Research and Operation Center performs the following tasks as operation management works for the JGN IPv6 network.

- Management of IPv6 addresses and

assignment

- Management of network topology and monitoring of routing information
 - Management of IPv6 servers, e.g., name servers and WEB servers.
 - Interconnection with other IPv6 networks
- The center is also developing the network management tools and a traffic collecting and monitoring system.

第5章 An Evaluation of IPv6 Multicast Router in JGN IPv6 Networks

This chapter describes an evaluation of IPv6 multicast routers. The JGN IPv6 project has performed various evaluations and verifications of IPv6 routers. Seven (7) types of routers from six vendors were tested, for which PIM-SM was employed as an IPv6 multicast protocol for the evaluation. The evaluated items include PIM-SM interoperability, as well as detour, RP and BSR behavior. Several tests were performed on ATM and Ethernet connections. Detailed results of these verifications are shown in this report. No fatal problems were found and only a few minor issues occurred while conducting these evaluations.

5.1 Background

Multicasting is becoming more necessary and important in broadband environments. During IPv4, the multicast was implemented in many routers, yet it was not widely used due mainly to the implementation of IGMP snooping function in connected switches, problems in network bandwidth used, as well as insufficient performance in multicast packet transaction of the routers themselves. Thus, its interoperability was not criticized.

In current IPv6 environments, the bandwidth problem does not exist, while problems in transaction efficiency were solved by improving

performance by using a hardware-based transaction circuit. That led ultimately to successes in multicast.

To verify its interoperability means that multicast can be realized from among different network organizations, while new services, which appear, are expected to act as part of the social infrastructure in the future.

5.2 Research Details

5.2.1 Router's IPv6 compatibility

We have evaluated IPv6[54] routers on their performance and functionality based on their interoperability. The targets of the evaluation are focused on basic communication, performance, unicast routing protocols and mandatory functions as in IPv4. At present, the verification of OSPFv3[41] routing protocol has been completed, and construction of a backbone network using routers possessed by the JGNv6[319] project can be realized. The deployment of OSPFv3 in

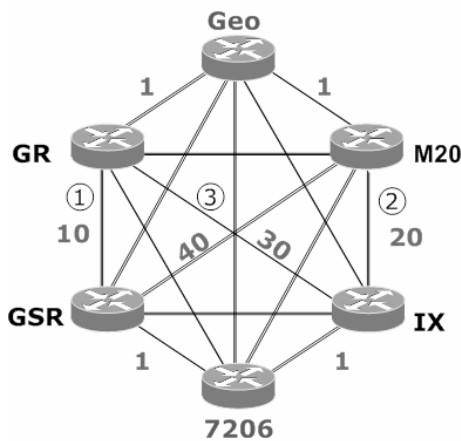

Fig. 5.1. Example of OSPFv3 Evaluation Network Structure.

JGNv6 network is coming to fruition.

5.3 IPv6 Multicast Implementation Status

5.3.1 Evaluation Data

The evaluated items are as follows:

- (1) Unicast Routing: OSPFv3
- (2) Multicast Group Management: MLD[53]
- (3) Multicast Routing: PIM-SM[81]
- (4) Multicast Group Address: ff18::xy

The reasons why PIM-SM was selected in the evaluation of IPv6 multicast were that there was no other choice when scalability in large-scale networks was considered, while PIM-SM was implemented by router vendors ahead of other protocols. This protocol is standard in current IPv6 multicast.

Despite this, some vendors only implement PIM-SSM[20], which is an extension of PIM-SM. A specific example is Juniper's M20 router. Yet it does not support unicast tunnel function between the DR (Designated Router) and RP (Rendezvous Point) in PIM-SM. It works when the router is neither a RP nor source DR, thus the evaluation was performed under this condition. The versions of router software that were employed in the evaluation are shown in Table 5.1.

5.3.2 Implementation status

The evaluated routers are possessed by TAO, or introduced by router vendors. Some of the routers introduced in JGNv6 did not support IPv6 multicast. In these instances, the router's successors were employed for the evaluation. The status of implementation is as shown in Table 5.2.

Table 5.1. List of Operating Systems in Each Routers

Vendor Name	Router	OS
Cisco Systems	GSR12406	IOS 12.0(26)S Patch Ver
	7206VXR(NPE3000)	IOS 12.3(2)
Juniper Networks	M20	JUNOS6.0 R1.5
HITACHI	GR2000-6H	S-9181-61 07-03-/C
NEC	IX5030	7.6.20
FUJITSU	GeoStream R920	E10V03L50C09
Furukawa	FITELnet-G20	v01.32

Table 5.2. Implementation Status

Vendor	Product	Static-RP	BSR
Cisco Systems	GSR12406		(Special IOS)
	7206VXR		(Special IOS)
Juniper Networks	M20		× (PIM-SSM)
Hitachi	GR2000-6H	×	
NEC	IX5030		
Fujitsu	GeoStream R920		
Furukawa	FITELnet-G20		

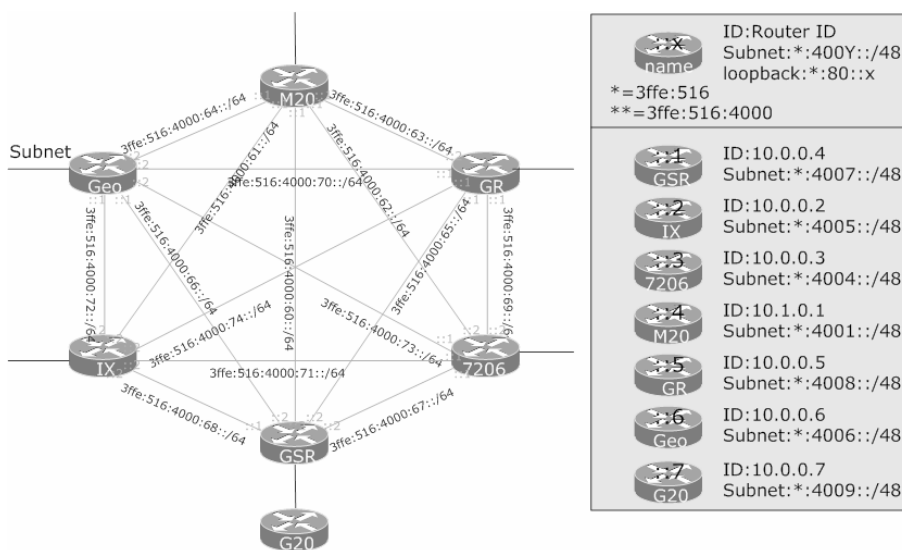

Fig. 5.2. Network Topology of the Evaluation in ATM Connection

5.3.3 Evaluated items

The following items were selected as mandatory functions for IPv6 multicast evaluated items:

- (1) Basic evaluation of PIM-SM interoperability
- (2) PIM-SM/OSPFv3 detour function behavior
- (3) Evaluation of RP behavior
- (4) Evaluation of BSR behavior

Items (1) to (3) were evaluated in ATM point-to-point connection topology (Figure 5.2), while item (4) was evaluated in an Ethernet broadcast environment (Figure 5.3) in considering actual operations on JGNv6 networks. Furukawa’s FITELnet-G20, which does not have an ATM interface, was connected via GSR12406 in ATM point-to-point connection topology.

5.4 Results of Interoperability Evaluation

5.4.1 Evaluation in ATM connection (1)–(3)

5.4.1.1 Connection topology of basic evaluation in PIM-SM interoperability

Firstly, basic connections in PIM-SM were evaluated before the evaluation of each function. The reason to perform this evaluation is that there were no known examinations of PIM-SM evaluation with so many types of routers such as those used in this evaluation, while the software brought by vendors included special versions. The specific connection topology is shown in Figure 5.4. Interoperability of all routers can be evaluated in the simplest fashion, by employing GR2000-6H, as described in the implementation status section, which cannot be a static RP, as RP, BSR, and source. DVcommXP by Fatware and DVTS by WIDE project were employed in all evaluations.

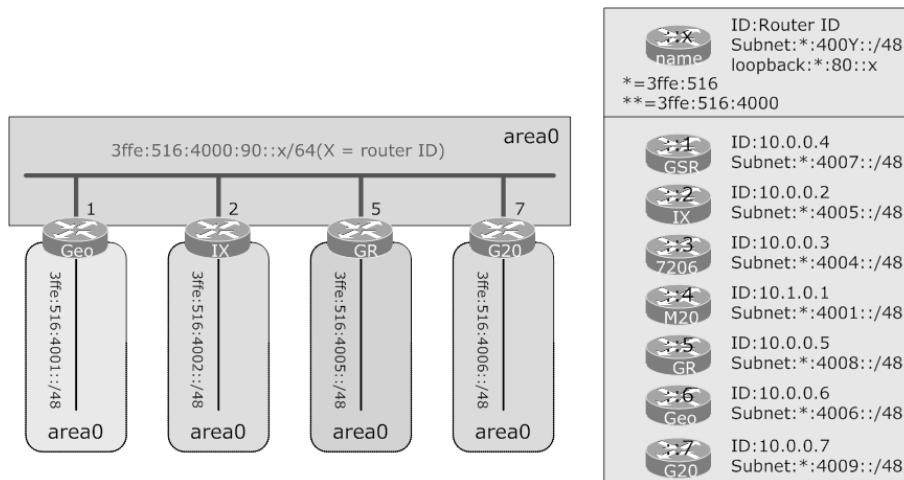

Fig. 5.3. Network Topology of the Evaluation in Ethernet Connection

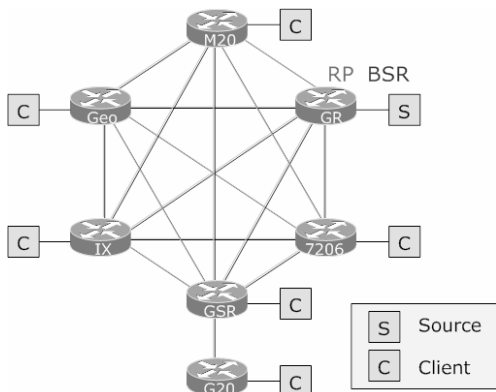

Fig. 5.4. Connection Topology of Basic Evaluation

PIM-Hello Option Compatibility

Point-to-point addresses of ATM interfaces are originally link-local addresses. However, in this evaluation, global addresses were assigned, while PIM-Hello option compatibility and its behavior were confirmed[275]. Though it was found that M20 did not perform the PIM Hello option, it ignored the option and no problem was discovered in its communication.

```
Aug 28 16:17:38 PIM Hello Unknown option: 65001
16:24:25.503754 Out fe80::2a0:a5ff:fe3d:1b42 >
ff02::d pim v2 Hello (Hold-time 1m45s)(OLD-DR-
Priority: 1) [class 0xc0] [hlim1]
PIM-Hello does not have any option in M20.
Aug 28 16:25:28 PIM at-0/0/0.61 SENT 3ffe:516:40
00:61::1 -> ff02::d V2 Hello hold 105 T-bit LAN
prune 500 ms override 2000 ms pri 1 sum 0x957f
```

len 26

Evaluation results of basic interoperability

Received messages in multicast clients under each router were confirmed. No problems were discovered in basic interoperability.

5.4.1.2 PIM-SM/OSPFv3 detour function behavior

One of the important PIM-SIM functions is multicast packet communication via the shortest path. This function was evaluated by detouring unicast route by OSPFv3, while IPv6 backbone was assumed.

ATM links were interrupted in numerical order, as shown in Figure 5.5. The router in which the route change occurred was confirmed to have received packets in the shortest path. To change routes immediately when interfaces go down, its logical interfaces were interrupted in software methods together with an opposite side router simultaneously.

Evaluation results of detour function

The time between the selection of the shortest path and receipt of packets are as shown in Table 5.3. Except for GeoStream, when each router received “Join” messages from the lower reaches, rerouting was performed and they were replicated into required interfaces. It was found that GeoStream waited query interval time before

Table 5.3. Selection of Shortest Path and Receipt of Packets

Shut-down	M20	GR	7200	GSR	G20	IX	Geo	Notes
GR-GEO	—	—	—	—	—	—	120 over	GEO's specification for MLD
GR-IX	—	—	—	—	—	8	—	
GR-GSR	—	—	—	11	—	—	—	
GR-7200	—	—	7	—	—	—	—	
IX-M20	—	—	—	—	—	32	—	
M20-7200	—	—	7	—	—	—	—	
M20-GSR	—	—	—	9	—	—	—	
Geo-7200	—	—	155	—	—	—	—	
IX-7200	—	—	×	—	—	—	—	
Geo-GSR	—	—	—	8	—	—	—	

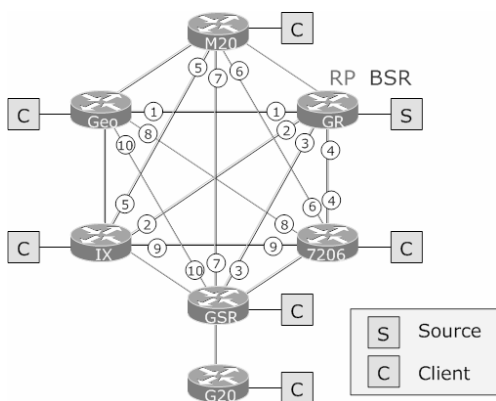

Fig. 5.5. Connection Topology of Basic Interoperability Evaluation

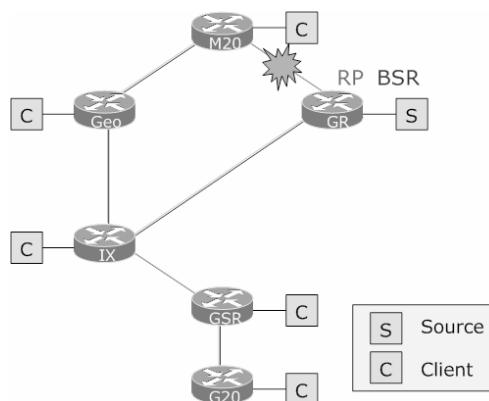

Fig. 5.6. Connection Topology when GSR

changing its PIM-Join target of in the specification.

Evaluation items in detour function

There are two items to be considered. The first is that GeoStream takes a long time to redistribute packets as it suppresses its load when encapsulation is performed. Yet, other routers do not show such phenomenon thus the problem was with GeoStream. This phenomenon was indicated to the router vendor that they were asked to consider it as such. The second item is that when the link 9 in Figure 5.5 was interrupted, IX did not receive assumed packets, which were replicated from GSR. This appears to be the following phenomenon between 7206 and IX:

- 7206:PIM Register Stop ⇒ IX:does not receive messages

However, it worked without any problems as GSR and 7206, GSR did not find PIM-Join from IX

between GSR and 7206 Were Eliminated and IX, while the same phenomenon was found to occur.

To solve this problem, connection topology was changed and GSR and 7206 were eliminated (Figure 5.6), and it was confirmed to work between IX and GeoStream. The problem was found between GSR and 7206.

The problem in special router software with BSR function was found, though contact with the vendors.

When router software in GSR and 7206 was changed to a previous one, no problem was found. Then, the evaluation was continued with the software without the BSR function.

5.4.1.3 Evaluation of RP behavior

Each router's behavior as RP was evaluated. For M20, which performs PIM-SM, as described above, the evaluations were performed where RP and DR, being neither RP nor source RP. The evaluation process is shown in Figure 5.7. RP,

BSR and Source were relocated under each router, while instances where RP is not source were also evaluated. Though this is not an ideal environment, such situations often occur in actual networks.

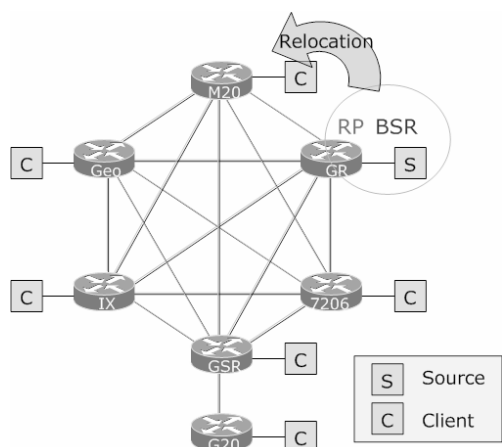

Fig. 5.7. Evaluation of RP Function

Evaluation results of RP behavior

The results of the evaluation are shown in Table 5.5. As shown in Table 5.5, when IX was RP and source was under GSR or 7206, replication did not work. The reason for this phenomenon was found to be that IX submitted “Register-Stop” without (S,G) and GSR did not send packets. It was found that the problem depended on how the vendor implemented this, thus the vendor was requested to make improvements.

5.4.2 Evaluation in Ethernet connection (4)

5.4.2.1 Evaluation topology of BSR function

The BSR function was evaluated for GeoStream, IX, GR and G20, which implemented this function. By evaluating each router’s match concerning RP and BSR, BSR problems that occur due to matching each router were clarified. Each group source was added under each router. As a result, four multicast groups existed in the network, which BSR and RP

Table 5.4. Results when GSR and 7206 Were Eliminated.

	M20	GR	G20	IX	Geo
GR-M20 shut down	4	—	—	5	—
GR-M20 no shut down	0	—	—	0	0

Table 5.5. Evaluation Results of RP Behavior

RP	Source	M20	GR	7200	GSR	G20	IX	Geo	Notes
M20	M20	1	1	1	1	1	1	1	
M20	×	—	—	—	—	—	—	—	M20 doesn’t support RP ≠ source
Geo	Geo	3	3	3	3	3	3	3	As a specification for joining simultaneously, it waits a certain period
Geo	IX	4	4	4	4	5	4	4	Bit rate of DVTS is limited to 20 Mbit/s due to OC/3
IX	IX	1	1	1	1	1	1	1	Bit rate of DVTS is limited to 20 Mbit/s due to OC/3
IX	GSR	—	—	—	—	—	—	—	The first test did not work, This phenomenon was confirmed twice. This was not due to the interoperability of PIM-SM, but that the NEC IX submits register-stop without creating (S,G).
Geo	GSR	—	—	—	—	—	—	—	The problem did not occur in the second test. Packet flow was shown to be normal. The vendor said it might be due to an internal problem in GEO when it was evaluated.
GSR	GSR	1	1	1	1	1	1	1	
GSR	G20	1	1	1	1	1	1	1	
G20	G20	1	1	1	1	1	1	1	
G20	7200	1	1	1	1	1	1	1	Bit rate of DVTS is limited to 20 Mbit/s due to OC/3
7200	7200	1	1	1	1	1	1	1	Bit rate of DVTS is limited to 20 Mbit/s due to OC/3
7200	Geo	1	1	1	1	1	1	1	Each router performed under 2000 pps. Block noise occurred because the bandwidth usage was 22 Mbit/s.
IX	7200	—	—	—	—	—	—	1	The same problem as IX-GSR, Geo-GSR occurred. Routers except for local 7200 could not connect.
GSR	7200	Not Measured							

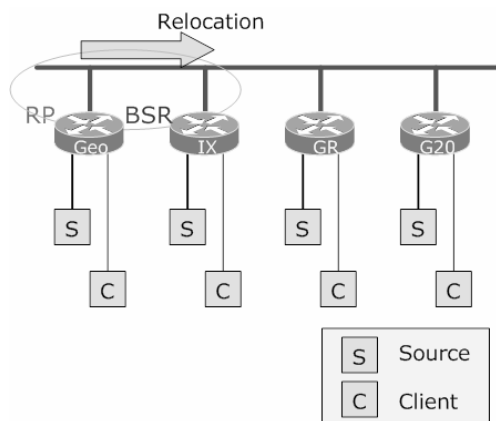

Fig. 5.8. BSR Function Verification

Table 5.6. Results of BSR Evaluation

BSR	GR	IX	Geo	G20
GR		—	—	—
IX	—			
Geo	—			
G20	—			

handled.

BSR and RP were switched by managing their priorities. For BSR, a larger value takes high priority, while a smaller value takes high priority for RP candidates. However, GeoStream cannot set RP priorities at present so its loopback address was set to the smallest value.

Evaluation results of BSR function and problems

Evaluation results of all matches are shown in Table 5.6. As shown in this table, GR were rarely evaluated. Problems were found when the source was placed under other routers. For this topology, GR can create correct (G,R) when GR was RP, BSR itself, and the source was under it, yet, when the source is under other routers, it cannot send (G,R) properly. This phenomenon occurred only when multiple PIM routers and multiple sources existed in a single broadcast network. Vendors were asked to investigate this phenomenon.

5.5 Discussion

As some routers do not have RP and BSR functions, an overall summary cannot be presented in

terms of IPv6 PIM-SM interoperability. However, concerning routers that implemented the functions, very few problems were located. At the practical operation level, there is sufficient performance for use by locating the RP, BSR and source in the proper locations. This can be used more efficiently if multicast applications that use smaller bandwidths are employed.

This evaluation was affected by bandwidth problems due to an over 30 Mbit/s DV stream. No problems should exist when all backbone routers are connected to high-speed circuits. However, if one of the routers is connected via a low speed circuit, it is sometimes flooded by relays from route changes. In this evaluation, 155 Mbit/s ATM circuits were flooded. This fact should be considered when actual networks are designed.

The evaluation results are fed back to each vendor. Router software version upgrades were requested to solve each problem.

第 6 章 Conclusions

In order that as large as possible number of research groups and organizations can participate in research and development related to IPv6 technology, the 47 access points in the JGN IPv6 network have been established in order to enable JGN to accommodate IPv6 traffic. The JGN IPv6 network is expected to establish how to introduce the IPv6 technology to the commercial network or to the multi vendor IPv6 networking environment. Considering the transition of the Internet from IPv4 to IPv6 (or we should say the introduction of IPv6 to the pure IPv4 network environment), it seems to be mandatory for the IPv6 network to be enable what has been enabled in the existing IPv4-based Internet. In addition, the following points are essential technical points, that we have to resolve;

- Methodology for assigning IPv4 and IPv6

addresses

- Methodology for upgrading and/or deploying hosts and routers
- Methodology for deploying IPv6-compatible DNSs
- A transition scenario in the individual sites toward the IPv6-compatible sites
- A transition scenario in the whole Internet toward the IPv6-based Internet

In the JGN IPv6 network, solutions for these issues has been investigated and examined through the operation of the live network. An introduction and evaluation of IPv6 technologies into the live experimental network (JGN IPv6 network) is essential to realize the following issues, e.g., operation control, security, load distribution, stream communication.

The JGN IPv6 network is a wide-area next generation experimental network that could resolve such market needs.

From now on, interconnection of this network with other IPv6 networks including oversea networks (e.g., Abeline in the USA) will be progressed. At the same time, the technical verification and evaluation of network equipments will be carried out.

Finally, the JGN IPv6 network is expected to serve as a field of acquisition and establishment of the IPv6 technology. The operators at the JGN IPv6 access points across the country (Japan) are convinced that useful experiences can be shared among the JGN IPv6 network users through the actual and live network operation.

From the practical operational point of view, one issue which caused concern was performance. For unicast performance, no problem was located in the various evaluation tests for target routers. However, some routers were expected to have performance problems in IPv6 multicast transactions. In practice, software-based relays were limited to temporary cases, when no route table was found, or where there was an encapsulated relay to RP. Hardware-based transactions are primarily employed, thus performance issues may

be disappear over time. However, the routers in JGNv6 project might be solved by making requests to vendors on performance problems. Consideration is needed when other routers are employed. In conclusion, the necessity of interoperability evaluations of different routers is realized. The evaluation of interoperability cannot be performed entirely in the vendor's laboratory alone. For example, some problems were discovered when a vendor brought a draft code to implement a new function, and their new codes were tested in their internal environment. The problems were revealed only during particular interfaces. Such problems are hard to find in their laboratory alone because some interfaces are normally unavailable there.

In the future, IPv6 multicast will be deployed in JGN IPv6 networks. Evaluations of multicast will be performed in real operating environments. In tested environments, no unicast traffic coexisted, thus unpredictable phenomenon might not occur. During IPv4, multicast was used in isolated networks; however, it will work as an infrastructure suitable to a ubiquitous society during IPv6.

Acknowledgements

We sincerely thank the persons who related with this JGN IPv6 project in Telecommunications Advancement Organizations of Japan (TAO). Also, we thanks to the Ministry of Public Management, Home Affairs, Posts and Telecommunications, who gave us the opportunity to be involved in the construction of the JGN IPv6 network. We would also like to take this opportunity to thank the network engineers who took part in the operation of the JGN IPv6 network for their cooperation.