

## 第XX部

# JGNv6プロジェクト



## 第20部

### JGNv6プロジェクト

---



---

#### 第1章 Abstract

---



---

The research and development on the IP version 6 (IPv6) has been progressed since the end of 90's, so as to resolve various technical problems for the continuously growing Internet, e.g., scarcity of IP addresses or the increase in the number of routing paths. WIDE project has worked on the research and development on the IPv6 technology from the very beginning of IPv6's technical discussion at the IETF, and has operated the native IPv6 nation-wide testbed network since around 1998. Telecommunications Advancement Organization (TAO) has operated Japan's nation-wide Gigabit Network (JGN: Japan Gigabit Network) since 1999, and has upgraded the network so as to be compatible with IP version 6 (IPv6). JGN IPv6 network maintains 47 public access points, that are capable of providing IPv6 services. There are two types of access points in the JGN IPv6 network. One is router site (28 sites) and the other is bridge site (19 sites). With this deployment, an IPv6 network has been developed enabling the execution of various verification and operation experiments, such as early transition of the network from IPv4 to IPv6 and the debugging of developed products in order to be compatible with IPv6.

The most of core sites (i.e., router sites) are overlapped with the JB project IPv6 network and the operation of the JGN IPv6 network has been achieved by the JB project NOC members. Here, as we have reported, JB project is a collaboration among the WIDE Project, ITRC and CKP (Cyber Kansai Project), and the major portion of the network is by WIDE Project.

In addition, IPv6 interoperability evaluation lab-

oratories have been set up in Okayama and at Makuhari (branch office) to execute the verification of interoperability between systems for current IPv6-compatible router equipments, and an IPv6 research and operation center has been set up in Tokyo (Otemachi) for developing operation and management technologies of the IPv6-compatible network equipment. This chapter describes the outline of the JGN IPv6 network from several aspects: a network topology, IPv6 router equipment manufactured by multi-vendors, setting up of the network such as an address space and routing, and open access points, and introduces research and development activities at the IPv6 interoperability and evaluation laboratories and the IPv6 system research and operation center that have been newly set up in constructing this network.

---



---

#### 第2章 Introduction

---



---

For the next generation very high-speed network, the Telecommunications Advancement Organization (hereinafter referred to as TAO) has established a gigabit network for research and development. JGN, Japan Gigabit Network, aims to contribute the research and development of network operation and management technologies, and advanced application technologies. JGN is an open research and development network for various research organizations, e.g., governmental agencies, or enterprises, as well as universities and research agencies [5]. To enable the JGN to accommodate various research and development activities related to IPv6 (Internet Protocol Version 6) technology, which is a core network protocol for the next generation Internet. Network equipments compatible with IPv6 has been installed and a test

operation as a JGN IPv6 network has started on October 1, 2001. It is said that IPv6 can provide; Various functions, such as security, reliability, which are required for emerging communication infrastructure

Address space, which is necessary and sufficient to preserve the end-to-end model. IPv6 has also been designed to cope with various problems arising from Internet protocol version 4, such as the problem of scarcity of IP addresses and increase in the number of routes in the Internet backbone. For example, IPv4 can accommodate only (about 4,300 million) hosts to be connected to the Internet, even if the whole of address space is assigned to host addresses, On the other hand, IPv6 accommodates (about 340 undecillion) hosts to be connected. Regarding the routing architecture, IPv6 is designed with the efficient routing aggregation. Most of IPv6 standardization has been achieved part several years ago, to introduce the IP version 6 to the real production network (RFC2460) [136], ICMPv6 (RFC2463) [16]. In these days, various kinds of functions for the configuration and operation of the IPv6 network has been standardized and those functions have started to be implemented by various commercial router vendors. The JGN IPv6 network has been established as a native IPv6 network equipped only with IPv6-compatible equipments. And, JGN allows IPv4 traffic via IPv4/IPv6 dualstack operation, i.e., capable of accommodating both IPv4 and IPv6. In order to contribute to the router vendors, JGN IPv6 network is operated with a multi-vendor environment that includes two US vendors and three Japanese router vendors. JGN IPv6 network contains the Okayama IPv6 Interoperability and Evaluation Laboratory and the Makuhari branch office. In these laboratory, we evaluate each network equipments and application software. The evaluation is functional compliancy of each equipment and interoperability among the network equipments. Also, the JGN IPv6 network has the IPv6 Research and Operation Center in Tokyo (Otemachi), in order to establish the oper-

ation and management technologies of the IPv6-compatible network equipments. As described above, the JGN IPv6 network has been developed for research and development of the network operation and management technologies, as well as the advanced application technologies. In order to join the JGN IPv6 network, the researcher proposes the research application, that is reviewed and evaluated by TAO [1].

---

### 第 3 章 Overview of JGN IPv6 network

---

#### 3.1 Network Topology

JGN networks uses ATM technology for datalink, and therefore, the JGN IPv6 network is sitting on the JGN 's ATM network. JGN IPv6 network has been constructed with 57 operational sites, which are 28 router sites and 29 bridge sites.

Among the router installation sites, we have four of core sites, i.e., the University of Tokyo, Teletport Okayama (in which the Okayama IPv6 Interoperability and Evaluation Laboratory is also set up), Dojima and the Kyushu University. Four core sites are interconnected to configure the backbone of the JGN IPv6 network. Other router sites are connected to one of the four core sites, and the bridge sites are connected to one of the router sites, respectively (Figure 3.1).

#### 3.2 Multivendor Environment

In order to establish the operational technologies and validate the interoperability among the routers manufactured by various vendors, the JGN IPv6 network contains different types of routers from five router vendors (See Table 3.1). Every router is commercial router, that is compatible with IPv6 functionality, though the software running in each router is sometime beta-code or alpha-code directly provided by each vendor.

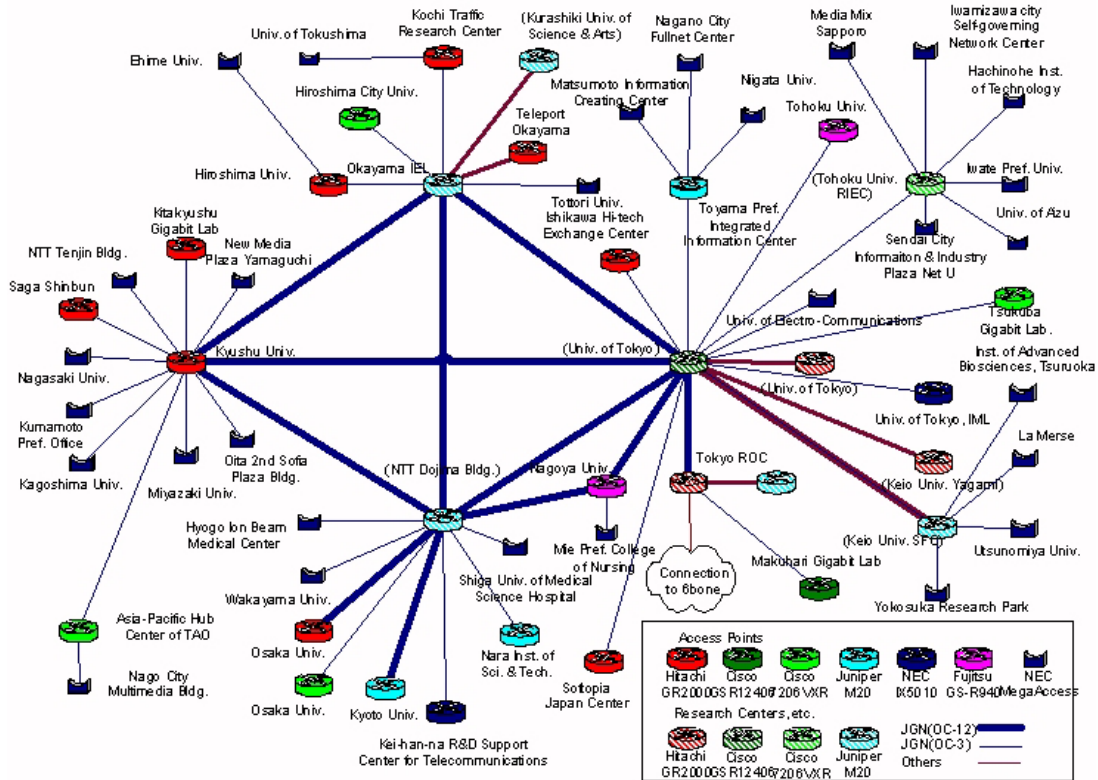

Fig. 3.1. Network Topology of JGN IPv6 Network

Table 3.1. Router in JGN IPv6 Network

| Vendor name      | Product name    | Num. of routers |
|------------------|-----------------|-----------------|
| Cisco Systems    | GSR12406        | 3               |
|                  | 7200VXR         | 6               |
| Juniper Networks | M20             | 8               |
| Hitachi Ltd.     | GR2000-6H       | 13              |
| Fujitsu Ltd.     | GeoStream R-940 | 3               |
| NEC Corporation  | IX5010          | 3               |

Each router vendor has their own interpretation for each protocol specification to have different implementation. Each router vendor has their implementation priority regarding the protocols and functions, that should be implemented as the IPv6 system. Therefore, it was sometime hard that all routers in the JGN IPv6 network has the same functionality and has the interoperability. For example, regarding the IGP (Interior Gateway Protocol), US vendors have implemented IS-IS first, however, Japanese vendors have imple-

mented OSPF first. With these diversity of functional and protocol implementation for each router vendors, we had to have serious consideration and cordination so as to operate every function and every protocol.

### 3.3 Routing Configuration

The JGN IPv6 network has partially inherited topological characteristics of the underlying ATM network. However, using the ATM virtual path (PVC), the logical network topology for layer 3 (IPv6) has been configured and has been sometime re-configured.

The current layer 3 network topology has been designed to establish the JGN IPv6 network easily for starting the stable initial operation. So that, the current layer 3 network topology is basically hub-and-spoke with four hubs (i.e., four core site with hierarchical topology). Router sites and bridge sites, excepting the core sites, are single-homing to each of their upstream site. According to the testing and evaluating items, the layer 3

network topology will be modified, when we need. Regarding the external connectivity, JGN IPv6 network uses BGP4+ for peering with other IPv6 networks. The JGN IPv6 network is connected to the WIDE NSPIXP-6[4] (Otemachi, Tokyo), and is also connected to 6Bone, which is a global IPv6 experimental network. Regarding connection with other IPv6 networks, connection with local IXs, such as NSPIXP-3 (Dojima, Osaka) and OKIX (Okayama), is also being considered. The current JGN IPv6 network (as of October 18, 2002) has the following 11 peerings ;

- WIDE Project (AS 2500)
- KDDI (AS 2516)
- Netsurf (AS 4675)
- FINE (AS 4678)
- MIND (AS 4680)
- PoweredCom (AS 4716)
- APAN Tokyo-XP (AS 7660)
- KDDI Laboratories (AS 7667)
- IPv6 Promotion Council Network (AS 17935)
- APII (AS 18083)
- NTT DoCoMo (AS 18262)

As for the IGP (Interior Gateway Protocol), we have to use RIPng rather than OSPF or IS-IS. This is simply because not all routers installed in the JGN IPv6 network support OSPF nor IS-IS. Finally, at this moment of time, JGN IPv6 network has not applied the multicast routing protocol. We are going to introduce the PIM-SM with IPv6, whenever all routers installed in the JGN IPv6 network support it. Some routers have already implemented the PIM-SM to make sure the interoperability among them, however some routers have not implemented yet. Whenever all routers are ready to enable OSPF (i.e., OSPFv3) or PIM-SM with IPv6, we will start to run these routing protocol on the JGN IPv6 network. An IPv6 address block employed in the JGN IPv6 network uses the NLA addresses (3ffe:516::/32) in a pTLA address block allocated by the WIDE Project[11]. A method for assigning addresses to each of the router site and the bridge site is recognized as one of the experiments associated with IPv6 operation. Although we use the WIDE NLA address space, JGN IPv6 network obtains own AS

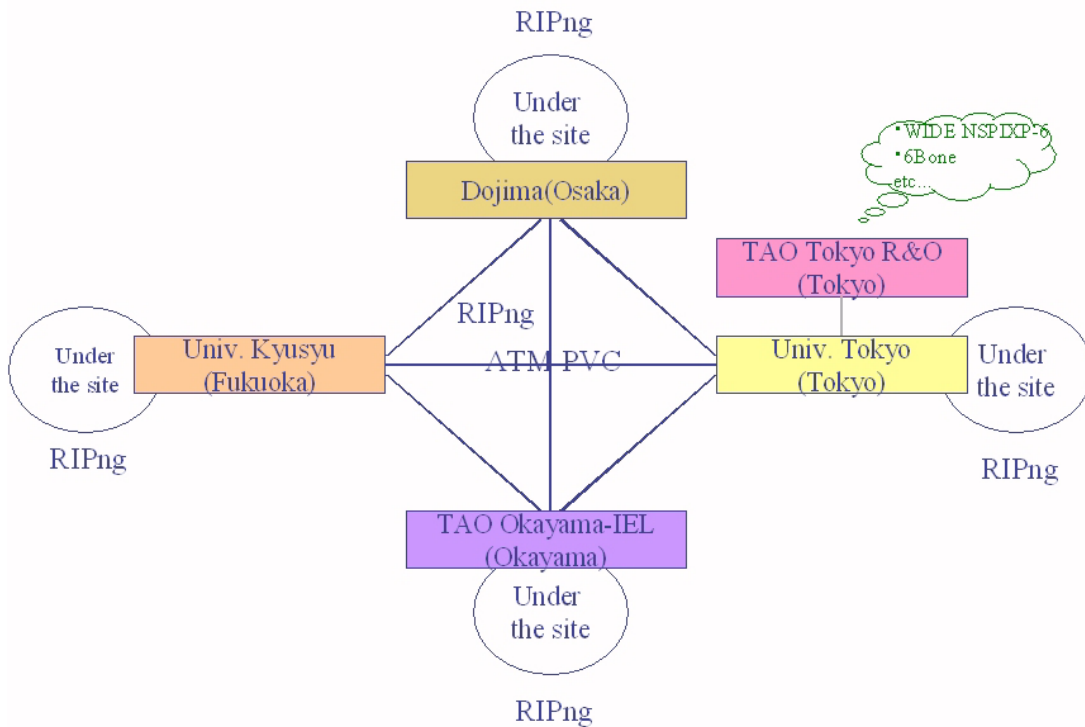

Fig. 3.2. Routing Configuration at the Initial Phase

W I D E P R O J E C T 2 0 0 2

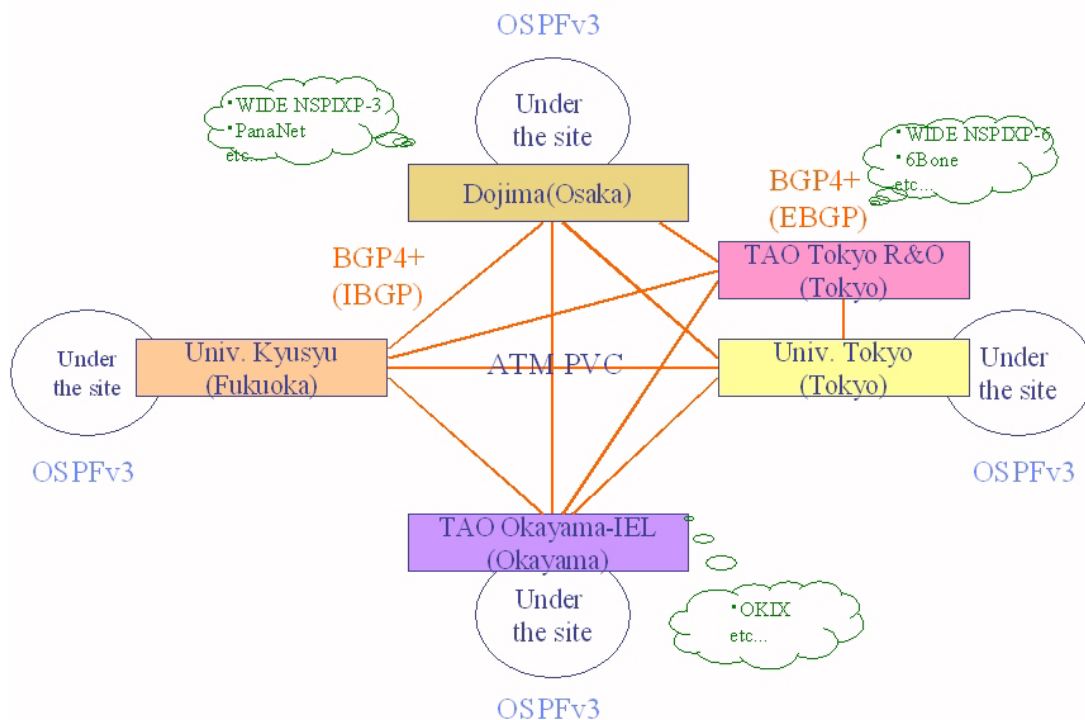

Fig. 3.3. Updating Routing Configuration

(Autonomous System) number (i.e., AS 17394), so that we can run experiments on exchange of the BGP routing information with other IPv6 networks.

**3.4 Installation of Network Equipments**

Among the 57 operation sites, 47 operation sites excluding some sites for research facilities are publicly opened as the access points (POP). Each access point provides IPv6 connectivity via Ethernet (10/100Mbps) to the JGN IPv6 network user. At each access point of the router sites, router, that has been compatible to IPv6, and an Ethernet switch accommodating the users are installed. Any user, who want to use the access point at the router site requests to interconnect to the JGN IPv6 network via Ethernet switch (10-/100BASE-T). At each router site, an address space of /48 is allocated for a segment for user accommodation. The bridge site provides an environment in which IPv6 can be used by extending the IPv6 segment (datalink). In order to bridge between the router site and bridge site, we use the

ATM-Ethernet bridge.

Figure 3.4 shows the default configuration of router site, and the Figure 3.5 shows the default configuration of bridge site.

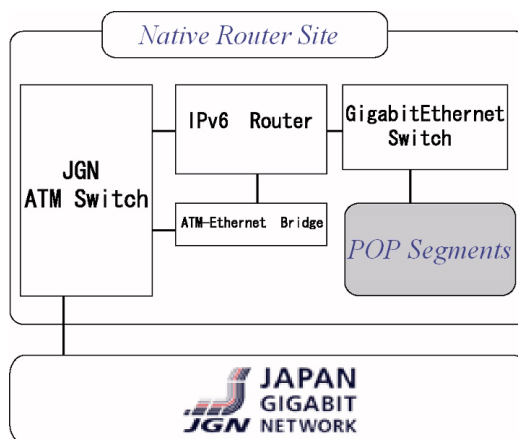

Fig. 3.4. Default configuration of router site

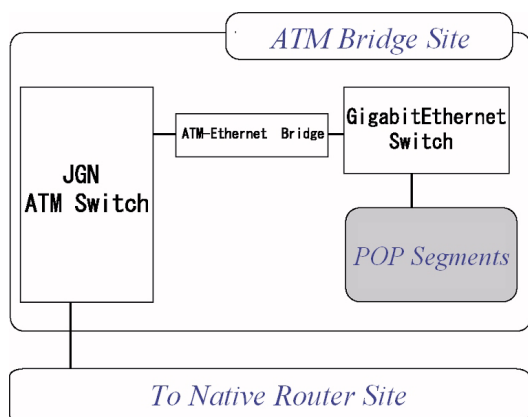

Fig. 3.5. Default configuration of bridge site

### 3.4.1 Network operation policy

In the JGN IPv6 network, the actual network operation and a monitoring work of the network itself deserve experimental approaches. Therefore, in the JGN IPv6 network, router installation sites have been newly set up at several locations that differ from the JGN IPv4 network access points that TAO has developed so far. By engaging in the daily operation of the network, the user is afforded the opportunity to learn network operation technologies of IPv6 different from those of IPv4. In the Internet, an operation form not assumed by a developer is often adopted. It is expected that with direct feedback from plural network administrators in the JGN IPv6 network, potential problems can be found at early stages. Tools and instrumentation systems for evaluating the compatibility and performance of IPv6 are also lacking and continue to do so. The WIDE Project has addressed the research and development of IPv6 from the early days. There have been many projects conducted: the world-famous KAME project[6] in which a program is being developed for providing an IPv6 stack for PC-UNIXs such as FreeBSD and NetBSD, the USAGI project[10] targeting Linux, the TAHI project[9] aiming at the exact implementation verification of IPv6, etc. In the JGN IPv6, it is necessary for as much cooperative work to be conducted with these projects as possible and for the technologies to be

shared so that IPv6 is popularized early. For that purpose, it is very important to store and share not only direct research achievements, but also information with respect to the processes in which these are obtained.

---

## 第 4 章 Verification and Evaluation of Interoperability

---

The current IPv6-compatible router equipments do not have full interoperability performance among those equipments manufactured by various vendors. Frankly saying, the capability of interoperability among IPv6 equipments would be similar to the status of IPv4 in ten years ago. The JGN IPv6 project executes the verification and evaluation of interoperability among the IPv6-compatible router equipments. For this research purpose, we have established the Okayama IPv6 Interoperability and Evaluation Laboratory. All pieces of the router equipments, that have been introduced in the JGN IPv6 network, are installed in the laboratory so as to be executed verification and evaluation. After the verification and evaluation at the laboratory, only the equipments working correctly and having the interoperability with other equipments are introduced into the JGN IPv6 network. The following items would be verification and evaluation items:

- Verification of accuracy and compliancy of IPv6 functions
- Performance evaluation
- Verification of interoperability between equipments supplied by various vendors
- Verification of availability and compatibility among equipments
- Verification of stability, failure tolerance, and etc.
- Verification of functions when being in a redundant network topology.

The IPv6-compatible router from each manufacturer experiences fairly frequent version up. This



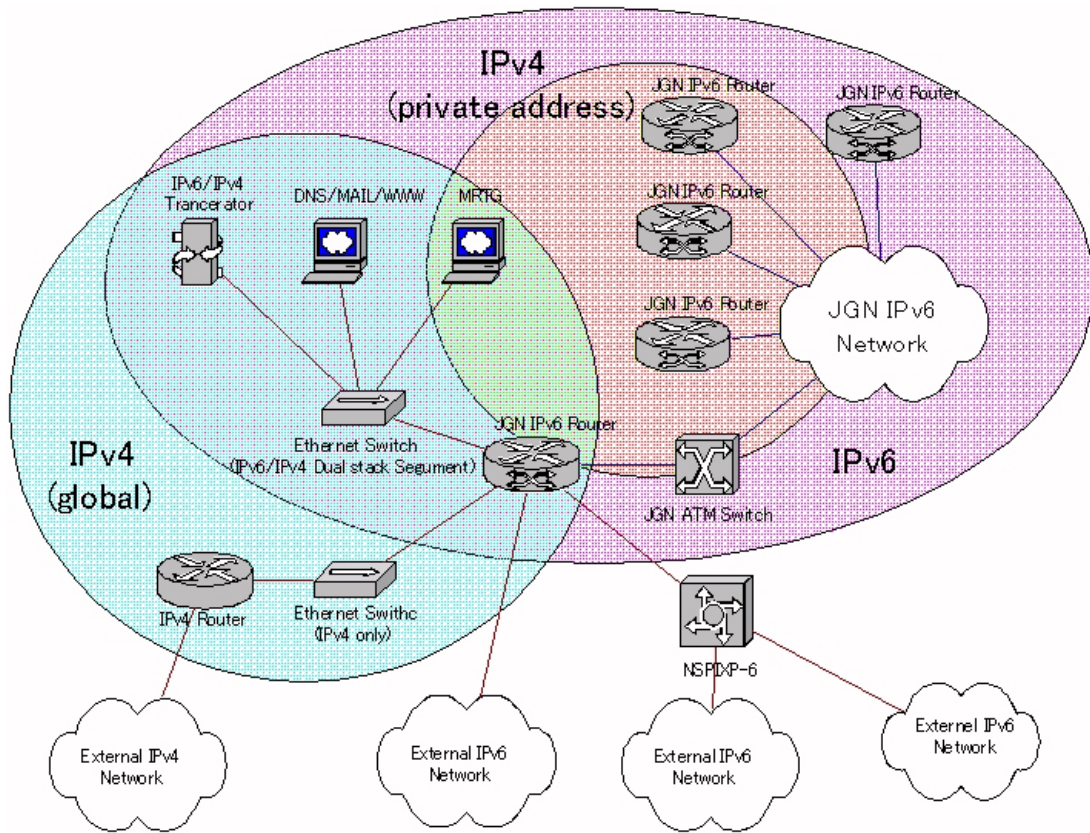

Fig. 3.6. IPv6 and IPv4 Operational Overview

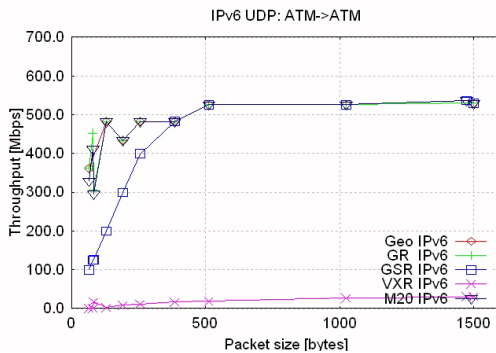

Fig. 4.1. Evaluation of Router's Throughput(I)

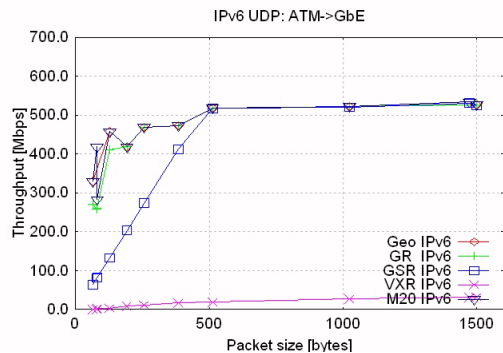

Fig. 4.2. Evaluation of Router's Throughput(II)

is because each manufacturer wants to implement a new function of IPv6 as much as and as fast as possible. They are fixing the technical problems for the software implementation at the router software with a short turn-around periods.

**第5章 Management Technology of IPv6 network**

Since SNMPv3[75], which is a network management protocol compatible with IPv6, is in the process of being standardized at the IETF, it would

be hard that the router products provided by the manufacturers are equipped with an IPv6-based network management capability. Similarly, almost all products of network management applications do not have an acceptable compatibility with IPv6. At least, the JGN IPv6 network should have the following functions;

- Capability to collect traffic information of an interface with an IPv6 address
- Capability to perform correct address notation corresponding to 128 bits,

The IPv6 Research and Operation Center in Otemachi (Tokyo) is in charge of the development of software required for operation and management for the actual operation of the JGN IPv6 network. The Research and Operation Center performs the following tasks as operation management works for the JGN IPv6 network.

- Management of IPv6 addresses and assignment
- Management of network topology and monitoring of routing information
- Management of IPv6 servers, e.g., name servers and Web servers.
- Interconnection with other IPv6 networks

The center is also developing the network management tools and a traffic collecting and monitoring system.

---

## 第 6 章 Conclusions

---

In order that as large as possible number of research groups and organizations can participate in research and development related to IPv6 technology, the 47 access points in the JGN IPv6 network have been established in order to enable JGN to accommodate IPv6 traffic. The JGN IPv6 network is expected to establish how to introduce the IPv6 technology to the commercial network or to the multi vendor IPv6 networking environment. Considering the transition of the Internet

from IPv4 to IPv6 (or we should say the introduction of IPv6 to the pure IPv4 network environment), it seems to be mandatory for the IPv6 network to be able what has been enabled in the existing IPv4-based Internet. In addition, the following points are essential technical points, that we have to resolved;

- Methodology for assigning IPv4 and IPv6 addresses
- Methodology for upgrading and/or deploying hosts and routers
- Methodology for deploying IPv6-compatible DNSs
- A transition scenario in the individual sites toward the IPv6-compatible sites
- A transition scenario in the whole Internet toward the IPv6-based Internet

In the JGN IPv6 network, solutions for these issues has been investigated and examined through the operation of the live network. An introduction and evaluation of IPv6 technologies into the live experimental network (JGN IPv6 network) is essential to realize the following issues, e.g., operation control, security, load distribution, stream communication. The JGN IPv6 network is a wide-area next generation experimental network that could resolve such market needs. From now on, interconnection of this network with other IPv6 networks including oversea networks (e.g., Abeline in the USA) will be progressed. At the same time, the technical verification and evaluation of network equipments will be carried out. Finally, the JGN IPv6 network is expected to serve as a field of acquisition and establishment of the IPv6 technology. The operators at the JGN IPv6 access points across the country (Japan) are convinced that useful experiences can be shared among the JGN IPv6 network users through the actual and live network operation.

### Acknowledgement

We sincerely thank the persons who related with this particular project in TAO. Also, we thanks to the Ministry of Public Management, Home Affairs, Posts and Telecommunications, who gave us

the opportunity to be involved in the construction of the JGN IPv6 network. The JGN IPv6 network is operated by a considerably large number of engineers including the network engineers. We would also like to take this opportunity to thank the network engineers who took part in the operation of the JGN IPv6 network for their cooperation.

